

## HOLEMAKER PRO 50

### #2 MORSE TAPER, DURABLE MULTI-PURPOSE MACHINE



**Cutters**  
52mm



**Twist Drills**  
23mm

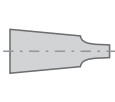

**Spindle**  
MT2

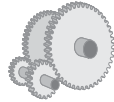

**Gearbox**  
200 rpm  
400 rpm

#### FEATURES

- Multi-purpose machine able to use Holemaker cutters, no. 2 Morse taper shank drills & reamers, as well as a drill chuck
- Industrial 2 speed gearbox
- Cast-iron motor housing
- Through spindle coolant system, with an external side mounted gravity feed coolant tank
- Left or right hand feed handle operation
- Unique semi-automatic gib adjustment system enables simple, fast and always correct fine tuning without any expert knowledge or experience
- Smart magnet technology to ensure sufficient magnetic adhesion
- Supplied in a metal carry case
- Suitable for steel fabrication, engineering workshops & maintenance facilities where a heavy-duty versatile machine is highly beneficial

#### HOLEMAKER

##### PRO 50 D (HMPRO50D)

The Holemaker Pro 50 is also available with an arbor for use with Holemaker cutters up to 75mm depth of cut

#### HOLEMAKER

##### PRO 50 QG (HMPRO50QG)

The Holemaker Pro 50 is also available with a quick release arbour system for a fast tool-less approach to inserting and removing Holemaker cutters



Part No.	<b>HMPRO50 (With Grub Screw Arbor)</b>
Part No.	<b>HMPRO50QG (With Quick Grip Arbor)</b>
Part No.	<b>HMPRO50D (With 75mm Depth Capacity)</b>
Capacity (Diameter)	52mm
Capacity (Depth)	52mm
Capacity (Twist Drills)	#2 Morse Taper 23mm
Motor Power	1260 Watt
Input Power	1340 Watt Single Phase 240V
Speed	2 Speed 200 / 400rpm
Weight	16.5kg
Magnetic Dead Lift	12,000Nm On 25mm Steel Plate
Stroke	153mm
Height (Min. / Max.)	426mm / 579mm

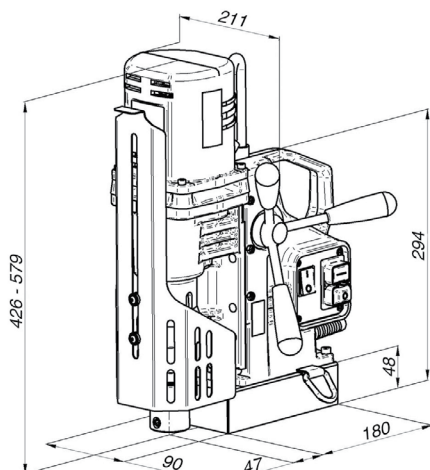

**EUROPEAN  
MADE QUALITY**

